

SAPHIR 2050 AT

HORIZONTAL

THE MOST COMPACT BALER IN THE RANGE

This fully automated horizontal 10 ton baler provides effective compaction where space is very limited. Ideal for shredded paper and low volumes of cardboard! The baler produces compact and lightweight bales and it can be delivered in two parts for easier transportation on site. We provide well-proven technology for special demands! The automatic tying and continuous baling allows multi-shift operation.

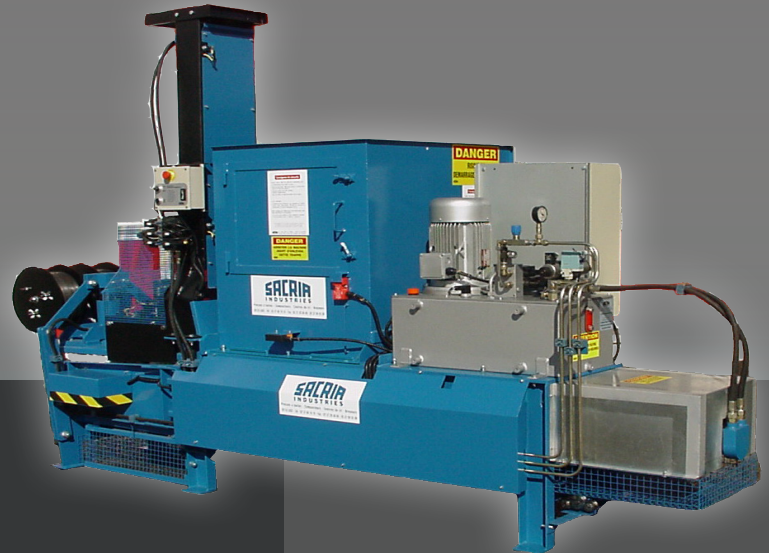

Automatic solution



0.7 T/H

CAPACITY
CARDBOARD

50 KG

BALE WEIGHT (UP TO)
CARDBOARD

Optimal features

WELL PROVEN TECHNOLOGY

based on more than 50 years of experience

AUTO START

equipped with photocell start as standard

HIGH SPEED

fast throughput of the material

ADJUSTABLE BALE LENGTH

individual settings to meet your needs

CHOICE BETWEEN VERTICAL & HORIZONTAL AUTOMATIC TYING

great versatility to bale different sorts of material



Benefits for you

- + Enhanced productivity thanks to the automated process
- + Improved internal and external logistics
- + Safe and comfortable working environment
- + More profitable waste management and increased income from sales of recyclables

www.pressor.fr

SAPHIR 2050 AT

Smart fully automated solution

OPTIMIZED FOR:

PAPER

+ Cardboard

PLASTIC

+ Shrink film
+ PET

METAL

+ Alu cans

COMPACT AND CLEVER DESIGN

The smallest baler in our Horizontal line fits where you need it to be! On demand, it can be delivered in two parts for easier transportation to the installation site.

CONTINUOUS FEEDING AND OUTPUT

A completely automated waste management solution designed for continuous infeed, automatic horizontal or vertical strapping system with adjustable wire links, which enables you to yield optimal output.

A VARIETY OF INFEED OPTIONS

To fit the conditions in your environment, our horizontal balers offer a wide choice of infeed systems: manual, by bin, air-transport and conveyor belt.

Our balers can also easily be equipped with shredders, bottle presses, rufflers, strippers and different types of hoppers.

SAPHIR 2050 AT

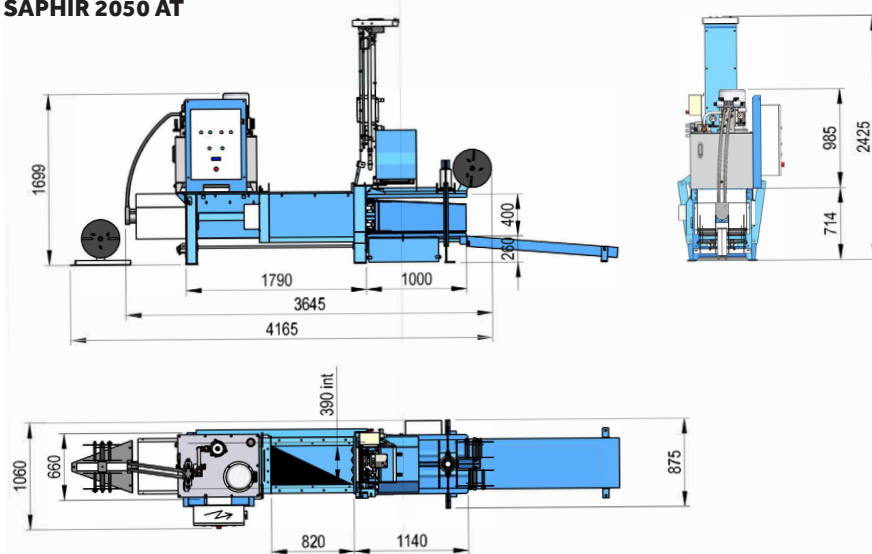

OPTIONS

+ HORIZONTAL TYING

+ BIN LIFTER

+ CONVEYOR BELT

+ COOLING & HEATING SYSTEMS

More special options on demand

DIMENSIONS & SPECIFICATIONS

TECHNICAL DATA

MODEL	2050 AT
Machine dimensions (LxWxH mm without bale exit)	4165x1060x2425
Feed opening (mm)	450x800
Infeed capacity (m³)	0.15
Press force (t)	10
Motor (kW / Hp)	7.5/10
Surface pressure (kg/cm²)	6
Cycles per minute	4
Channel section (mm)	450x400
Oil tank capacity (L)	80
Total machine weight (kg)	1150
Theoretical output (m³/h)	35
Loading output (m³/h)	21
Automatic binding	2 wires Ø 2.7
Bale size (mm)	450x400x
adjustable length (mm)	500-1000
Bale weight cardboard (kg)	20-50 kg
<i>depends on bale length</i>	



OPTION: CONVEYOR BELT



OPTION: BIN LIFTER

We reserve the right to make changes to specifications without prior notice. Bale weights are dependent upon material type.